

# HAND OPERATED SIRENS

## SIRENCO H100

This cast aluminium siren is designed as a backup alarm when there is a power failure or applications in remote areas where no electricity is available, blasting sites etc. This is a simple, maintenance free siren with a sealed gearbox.



SSAH100M | HAND OPERATED

## SPECIFICATIONS

SOUND OUTPUT	105dB(A)
APP. RANGE	500m in still open field
WEIGHT	1.2kg
PACKING DIMENSIONS	15.5x15.5x16mm

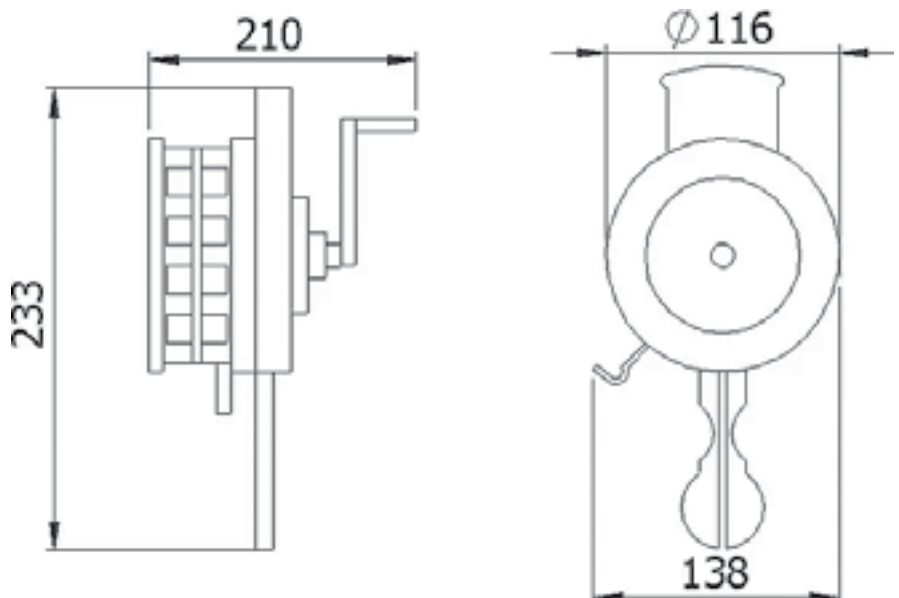

All dimensions in mm