

HAND OPERATED SIRENS



SIRENCO H150

This cast aluminium siren is designed as a backup alarm when there is a power failure or applications in remote areas where no electricity is available; blasting sites etc. this is a simple, maintenance free siren with a sealed gearbox. The lightweight tripod stand can be folded up for easy transport and is height adjustable.

SSH150C | HAND OPERATED

SPECIFICATIONS

SOUND OUTPUT	112dB(A) at 1m
SOUND FREQUENCY	500Hz
APP. RANGE	1000m In still air on open field
MOTOR	Sealed gearbox crank handle with ratchet
WEIGHT	5.1kg
PACKING DIMENSIONS	660x300x230mm

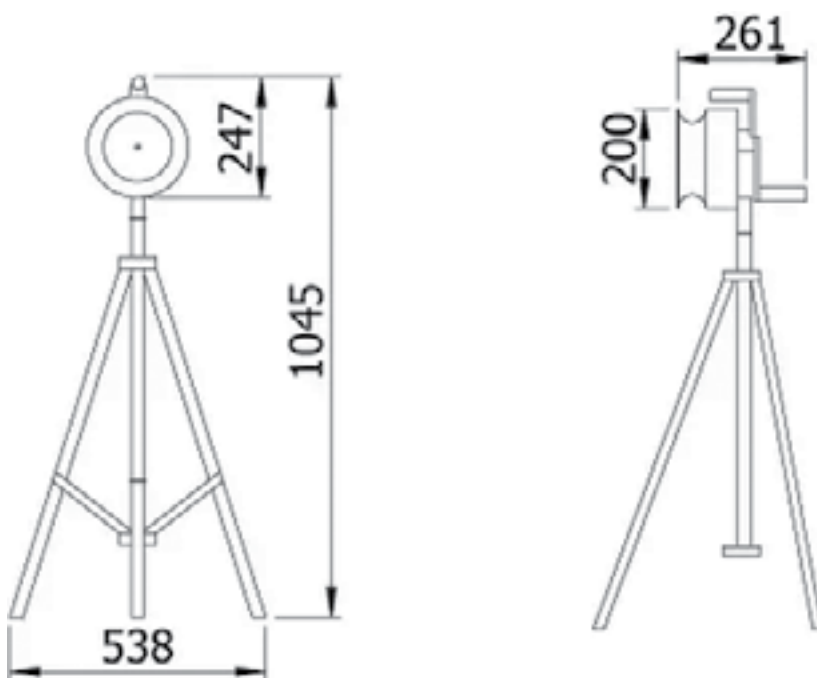

All dimensions in mm

