

# HAND OPERATED SIRENS

## SIRENCO H200

This cast aluminium siren is designed as a backup alarm when there is a power failure or applications in remote areas where no electricity is available, blasting sites etc. The handle on top of the siren can be selected to alter the sound output. This is a simple, maintenance free siren with a sealed gearbox.



SSH200C | HAND OPERATED

## SPECIFICATIONS

SOUND OUTPUT	120dB(A)
SOUND FREQUENCY	500Hz
APP. RANGE	2000m In still air on open field
MOTOR	Sealed gearbox crank handle with ratchet
WEIGHT	12kg
PACKING DIMENSIONS	560x360x450mm

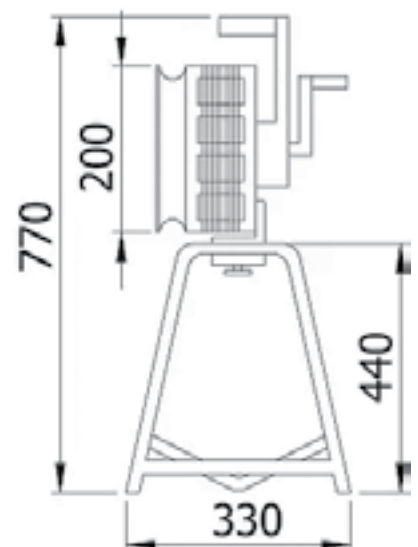
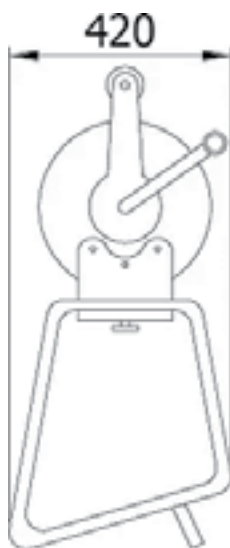

All dimensions in mm